



542 3rd St. Lake Elsinore CA 92530
Sales 951.245.8669



CORVETTE "C4" 1984-1996 Vertical Door Kit

U.S. PATENTS

#6,808,223; #6,845,547; #7,140,075; #7,059,655
PATENTS AGGRESSIVELY ENFORCED!





**PLEASE CAREFULLY READ ALL INSTRUCTIONS BEFORE
ATTEMPTING TO INSTALL THIS PRODUCT.**

**FOR QUESTIONS PLEASE
CONTACT US AT (951) 245.8669**

THIS KIT INCLUDES:

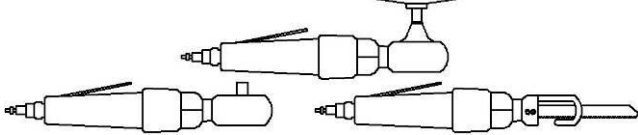
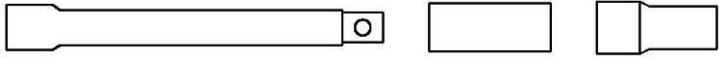
➤ 2 M8-1.25X40MM F.H.C.S.	➤ 2 SHOCKS 310 PSI
➤ 10 M8-1.25X30MM F.H.C.S	➤ 4 SHOULDER BOLTS
➤ RIGHT AND LEFT HINGE ASSEMBLY	➤ 2 PINS
➤	

TOOLS REQUIRED FOR INSTALLATION:

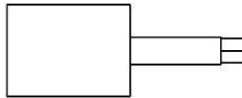
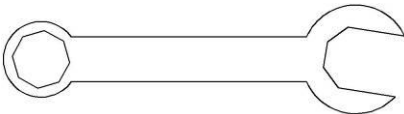
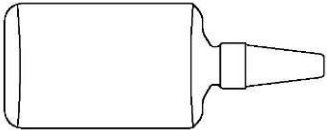
	➤ AIR RACHET, GRINDER AND CUTTER.
	➤ 7MM, 8MM, 10MM, 11MM, 13MM, SOCKETS AND EXTENSION.
	➤ FORK AND PHILLIP'S SCREW DRIVERS
	➤ SPACERS FOR THE DOOR GAP.
	➤ 3/16 ALLEN WRENCH
	➤ 1/4 & T15 TORX BIT
	➤ 9/16 WRENCH
	➤ LOCKTITE RED

OTHER TOOLS MAY BE NEEDED DEPENDING ON YOUR VEHICLE.

(Note: The pictures on the manual are for reference only they may not match your vehicle.)

Disconnect the battery.

Remove the Fender by removing the top bolt on two bolts on located by the door.



After removing the fender you will have to cut the wire boot bracket as shown.



Cut the wire boot in half as shown, do not cut the factory wires.

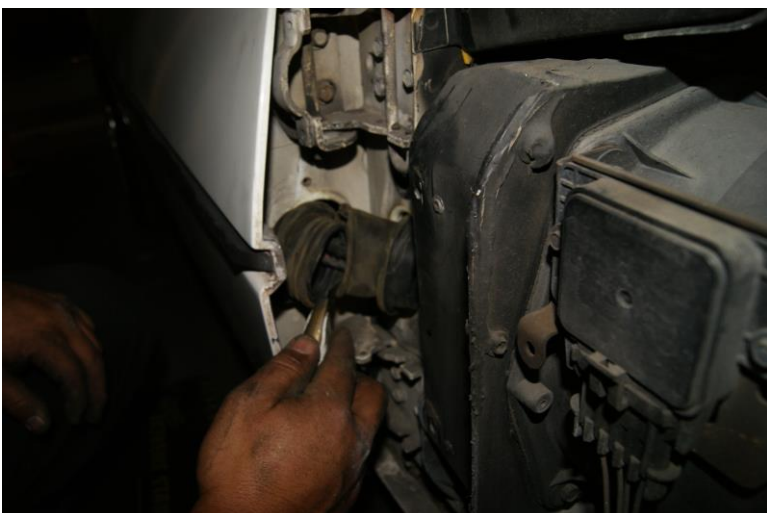

Very important:

Mark the factory location of the door. This will make it much easier to align the door after installing the new VDI hinge kit.

Use painters tape on the body and the door to mark the horizontal and vertical location also put tape near the top and bottom hinge, mark and measure the distance between the apron and the edge of the door.

Use 2" painters tape to secure the door to the body in preparation for factory hinge removal.

After securing the door to the body remove the factory hinges from the body.



Remove the door from the body of the car and place it on a "Work Stand" or something similar where it can be secure and safe from scratches.

Remove the factory hinges from the door.



After removing the factory door hinges you will have to take them apart.

You will need to use the ½ that goes to the door with your new VDI hinge. The ½ that goes to the body will not be used.

The GM hinges are clamped at the end to locked them in place you will need to round them with a grinder to get them off



After rounding the flats use a hammer to knock the pin off the hinge.



Do the same for the top and the bottom factory hinge.

You will have to modify the factory hinge ½ that goes to the door. Use the enclosed paper template and trace the top and bottom hinge as shown.

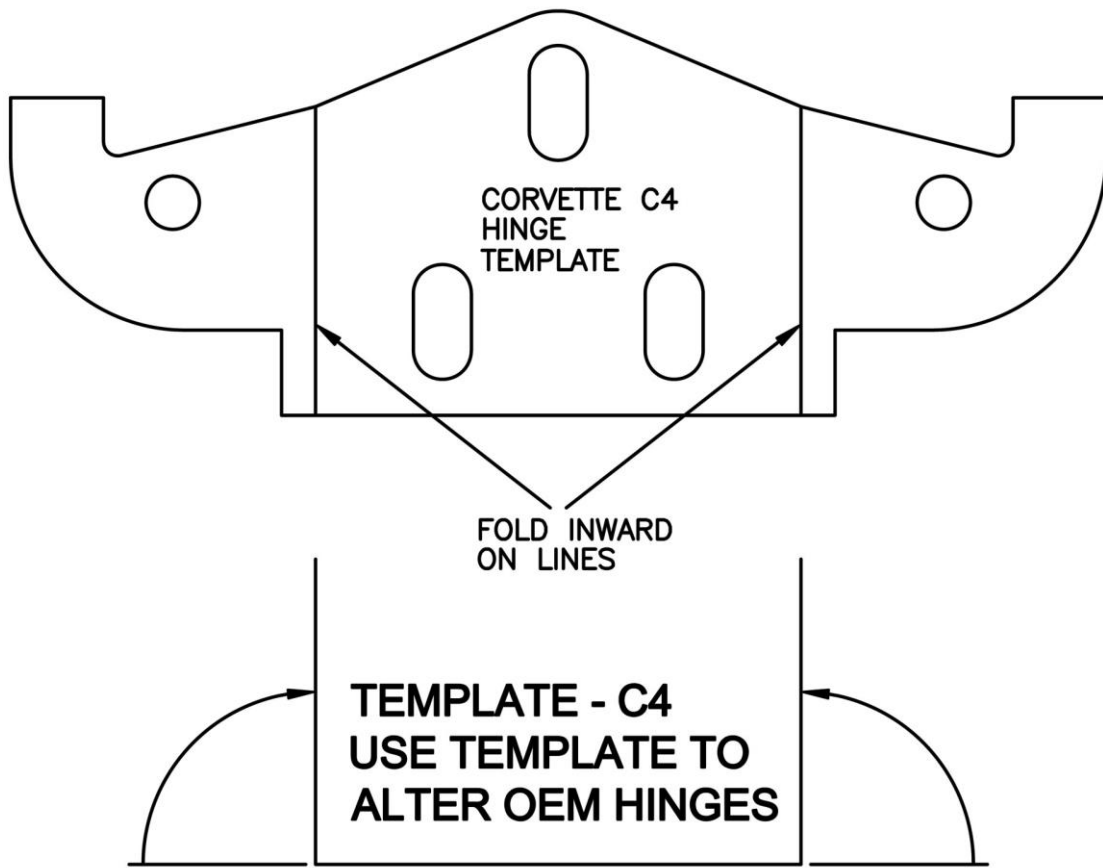

SEE ATTACHED TEMPLATE FOR A FULL SIZE VERSION

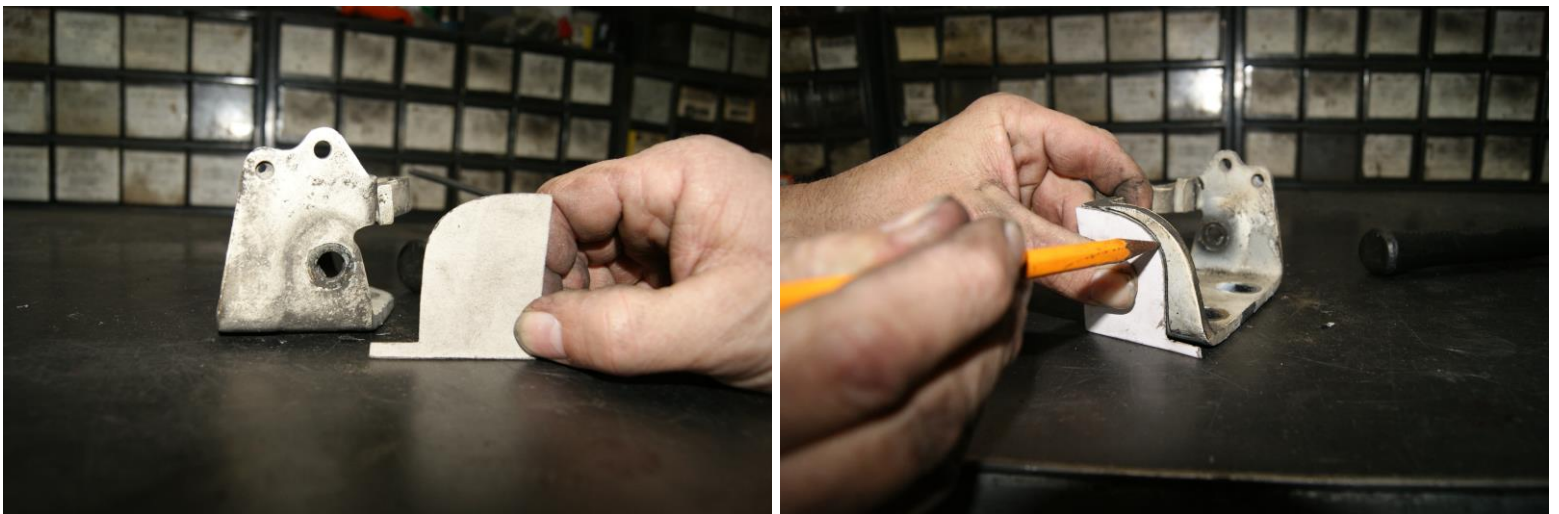

You will need to cut the parts that are marked with an "X"
By removing the marked metal it will allow the new VDI hinge to
more freely.

Install the factory hinge on the new VDI hinge make sure that the back of the factory hinge is at 90 degrees from the VDI hinge as shown on the image below

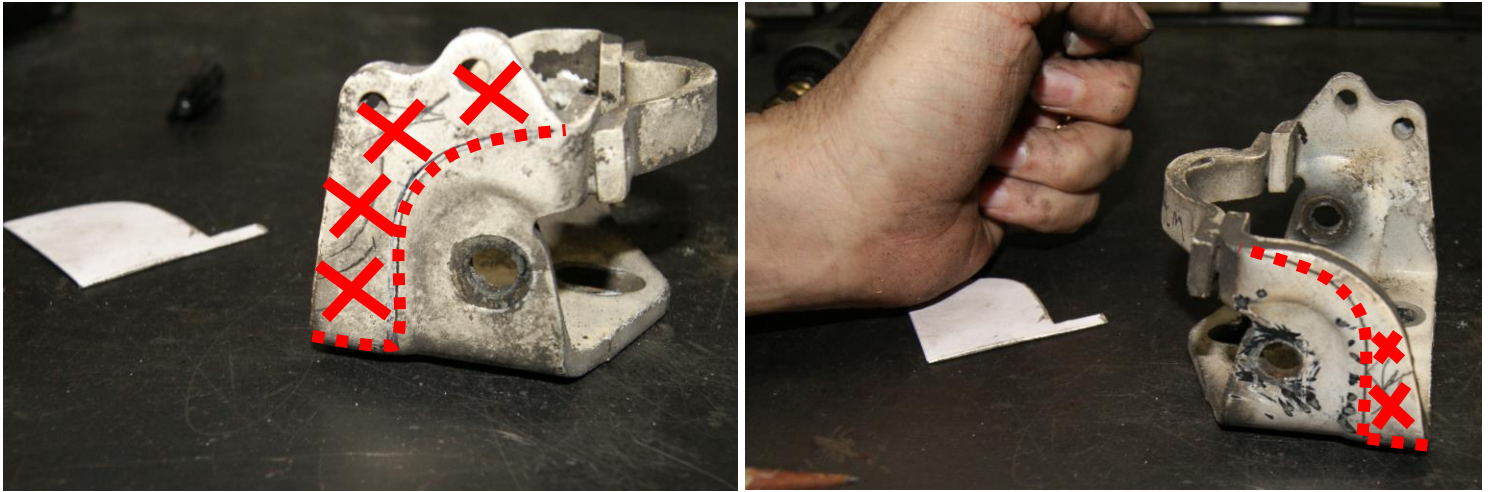
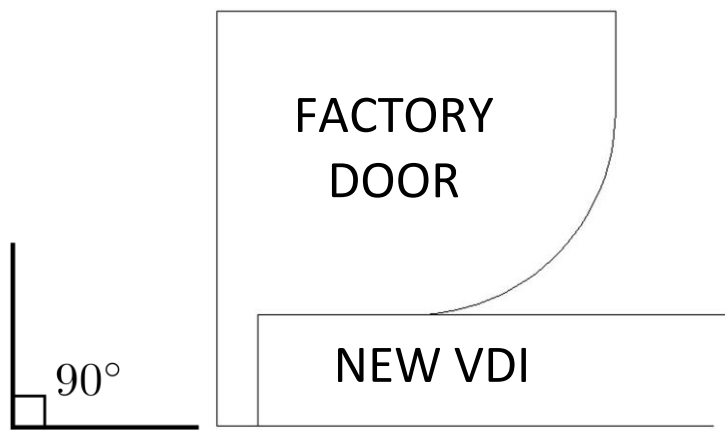
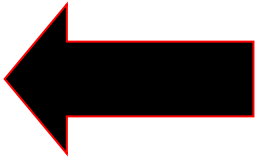
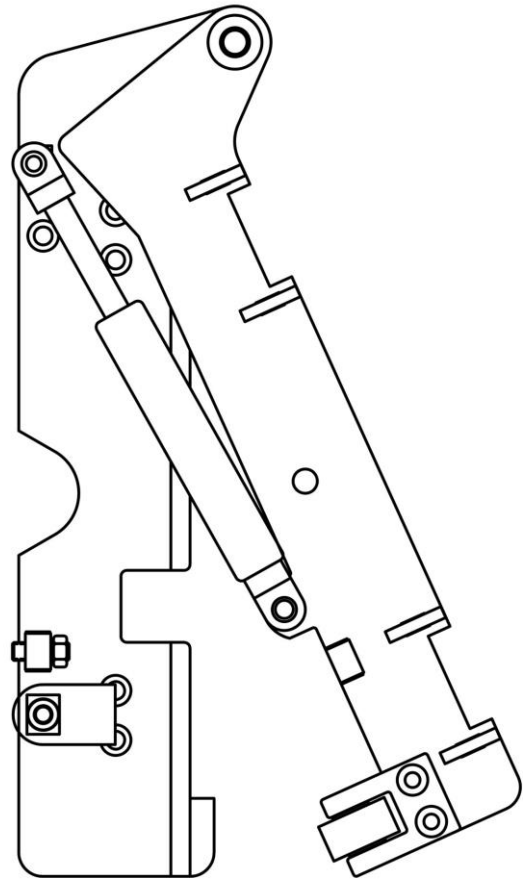

Image below as seen from the top of the hinge.





FRONT OF CAR



With the hinge you will get
10) M8-1.25X30MM (5 Per Side)
F.H.C.S.

You will also received
2) M8-1.25X40MM (1 Per Side)
F.H.C.S.

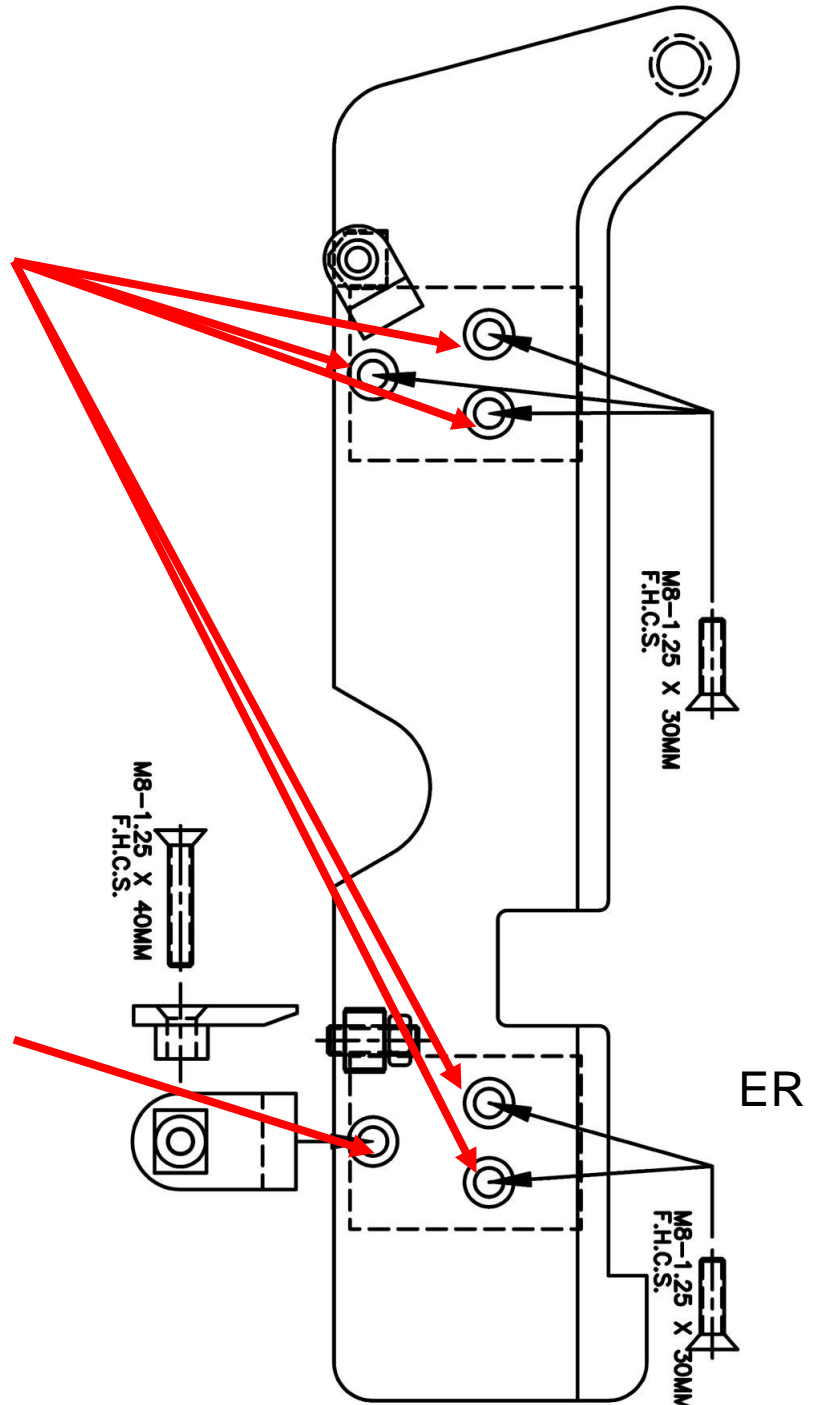

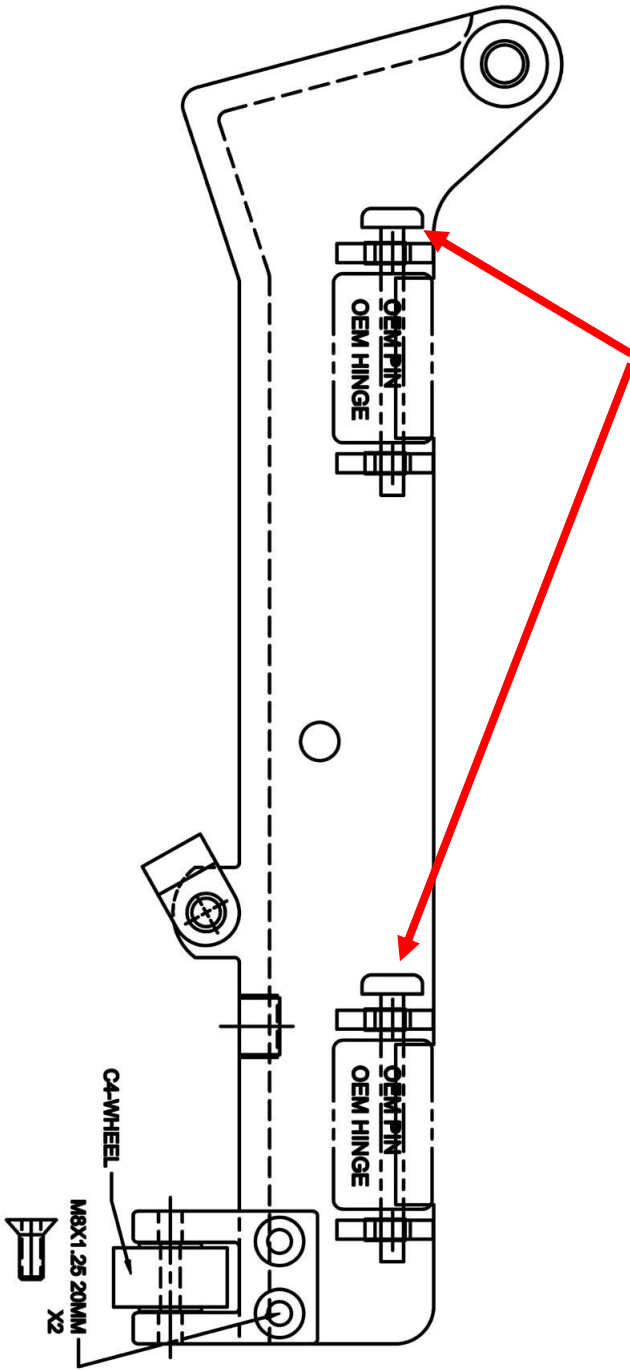

Modify the factory hinges and attached them to the new VDI hinge using the OEM pins.

Now that the hinge been assemble, install the hinge on the door as shown below.



You will need to remove the door panel and remove a few wire clips to gain the extra wire slack needed to allow the door to be raised up.

After insuring that the factory hinge is at 90 degrees from the new VDI hinge and that it moves freely you can now install the hinge on the car as shown



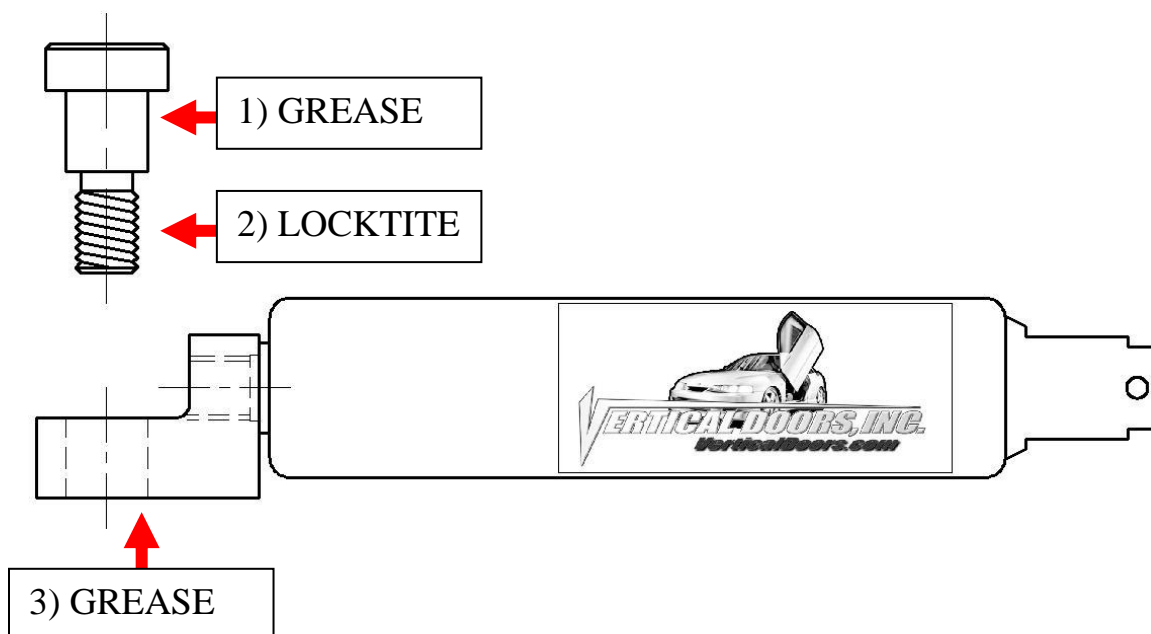

***IMPORTANT STEP: DO NOT SKIP THIS STEP. THIS STEP IS CRUCIAL IN YOUR INSTALLATION PROCESS, IF THIS STEP IS NOT COMPLETED WHEN INSTALLING THE VERTICAL DOOR KIT; ALL WARRANTIES ARE VOIDED, AND MAY CAUSE FUTURE PROBLEMS WITH YOUR VERTICAL DOOR SYSTEM.**

1ST, make sure you put grease on the body of shoulder bolt where the arrow is pointing.

2ND, make sure you put red Loctite, where the arrow is pointing, on thread of shoulder bolt.

3RD, make sure you put grease on the bottom side of the shock end.

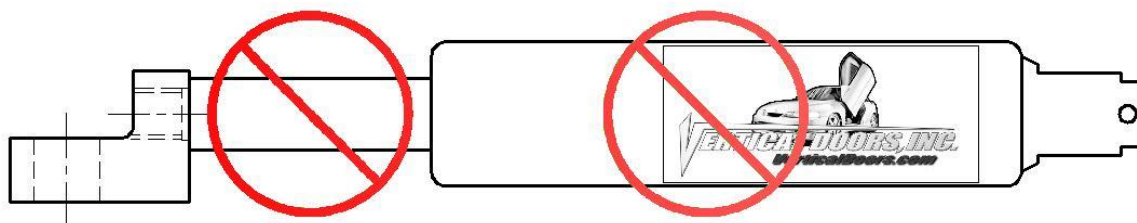

WARNING! THE USE OF ANY TYPE PLYERS, PAINT OR FOREIGN MATERIALS ON THE SHOCK'S BODY OR SHAFT WILL VOID THE WARRANTY.

For the other side just follow the same steps.

Thank you for your purchase of the
CORVETTE C-4

VERTICAL DOORS INC. SYSTEM

NOTE:

Vertical Doors Inc. assumes no responsibility for any damages caused by improper installation.